

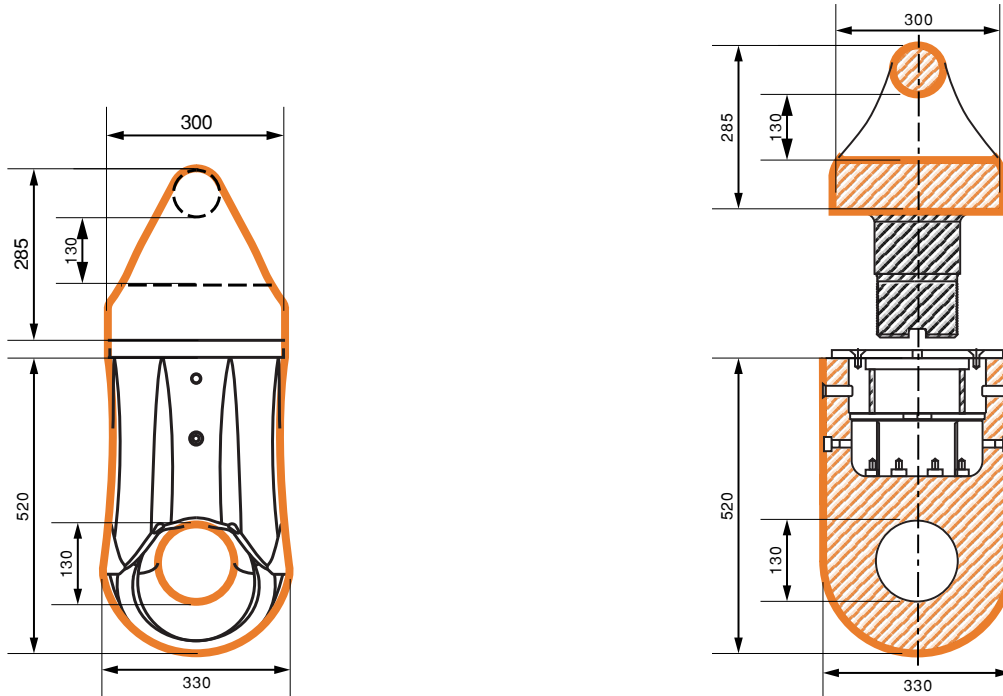

Dacmatech Swivel – Offshore Chain



Proof Load	Break Load	Steel Quality	Weight
mT	mT		kg
460	723	34CrNiMo6+QT	315

Loading Diagram with different test loads:

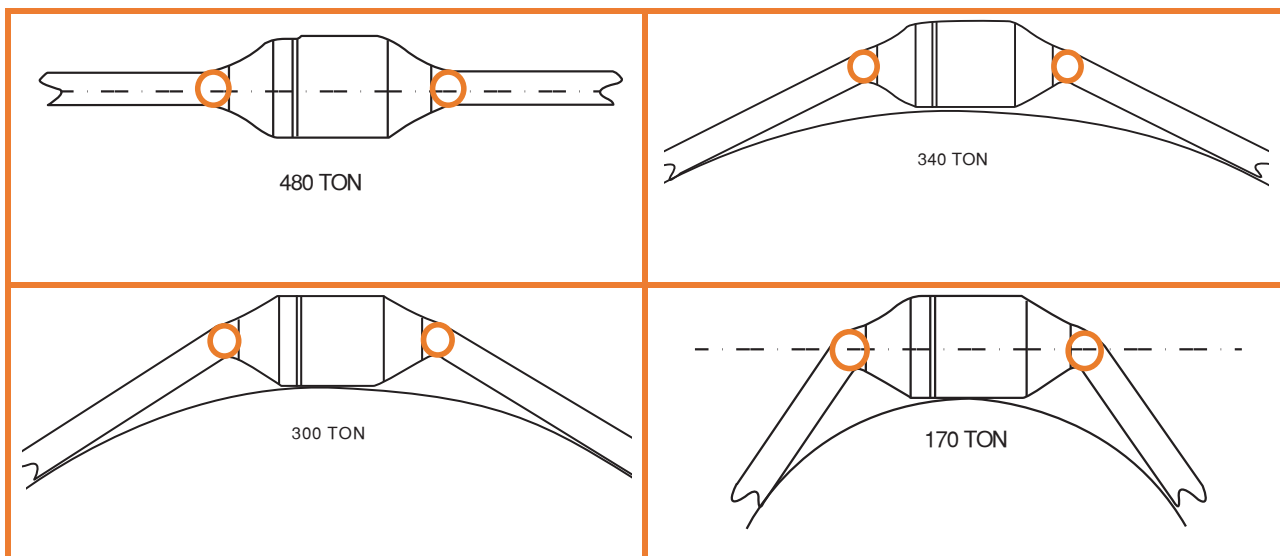

Weight unit is Kilograms. All measurements in mm. Measurements, weights, and drawings, are based on industry standards. Deviation margins need to be taken in mind, this is your own responsibility and not from Castle Hills AS.