

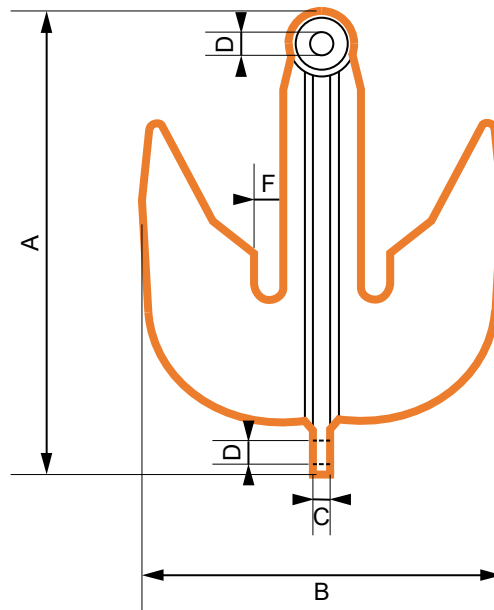

Grapnel Hook – Chain Chasers

For mooring applications

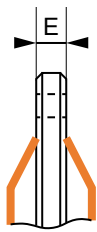

Type	SWL	Proof Load	Weight	A	B	C	D	E	F
99	50	80	400	1306	883	82	90	82	80
109	100	150	1351	1372	1178	75	98	135	108
129	200	270	1850	1822	1499	90	114	130	108
139	250	350	2630	1994	1676	100	144	190	127

Weight unit is Kilograms. All measurements in mm. Measurements, weights, and drawings, are based on industry standards. Deviation margins need to be taken in mind, this is your own responsibility and not from Castle Hills AS.