

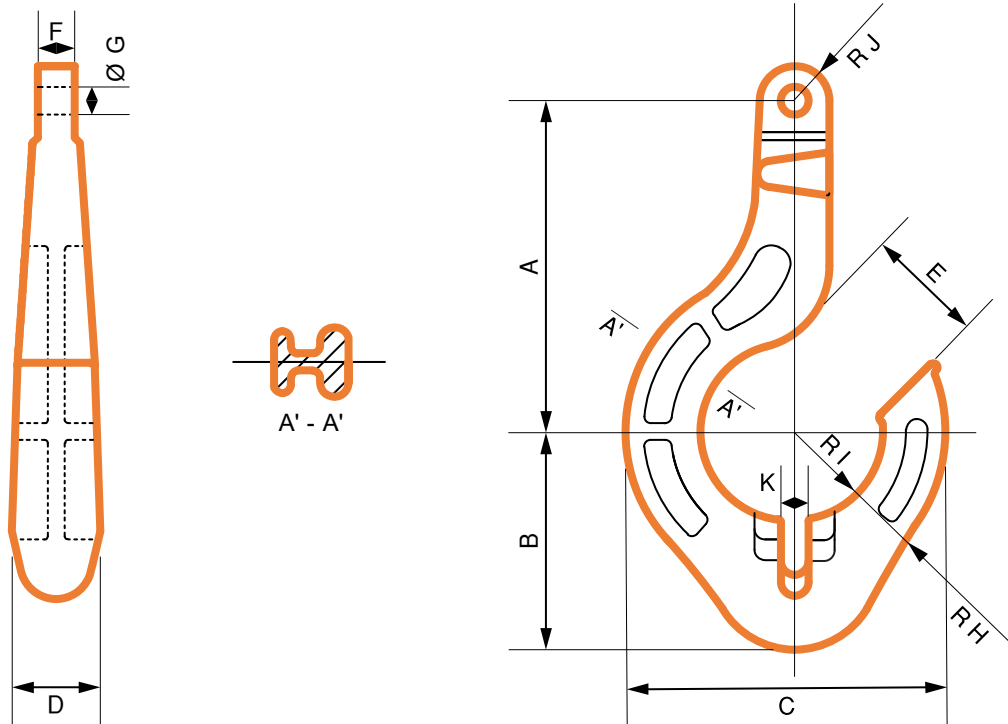

J-Lock – Chain Chasers

For mooring applications



| WLL | Weight | A | B | C | D | E | F | G | H | I | J | K |
|-----|--------|------|------|------|-----|-----|-----|-----|-----|-----|-----|-----|
| 150 | 2300 | 1339 | 883 | 1295 | 420 | 476 | 149 | 112 | 648 | 714 | 140 | 111 |
| 250 | 2700 | 1575 | 1041 | 1528 | 530 | 546 | 175 | 132 | 765 | 840 | 165 | 130 |

Weight unit is Kilograms. All measurements in mm. Measurements, weights, and drawings, are based on industry standards. Deviation margins need to be taken in mind, this is your own responsibility and not from Castle Hills AS.