

PNEUMATIC FENDERS

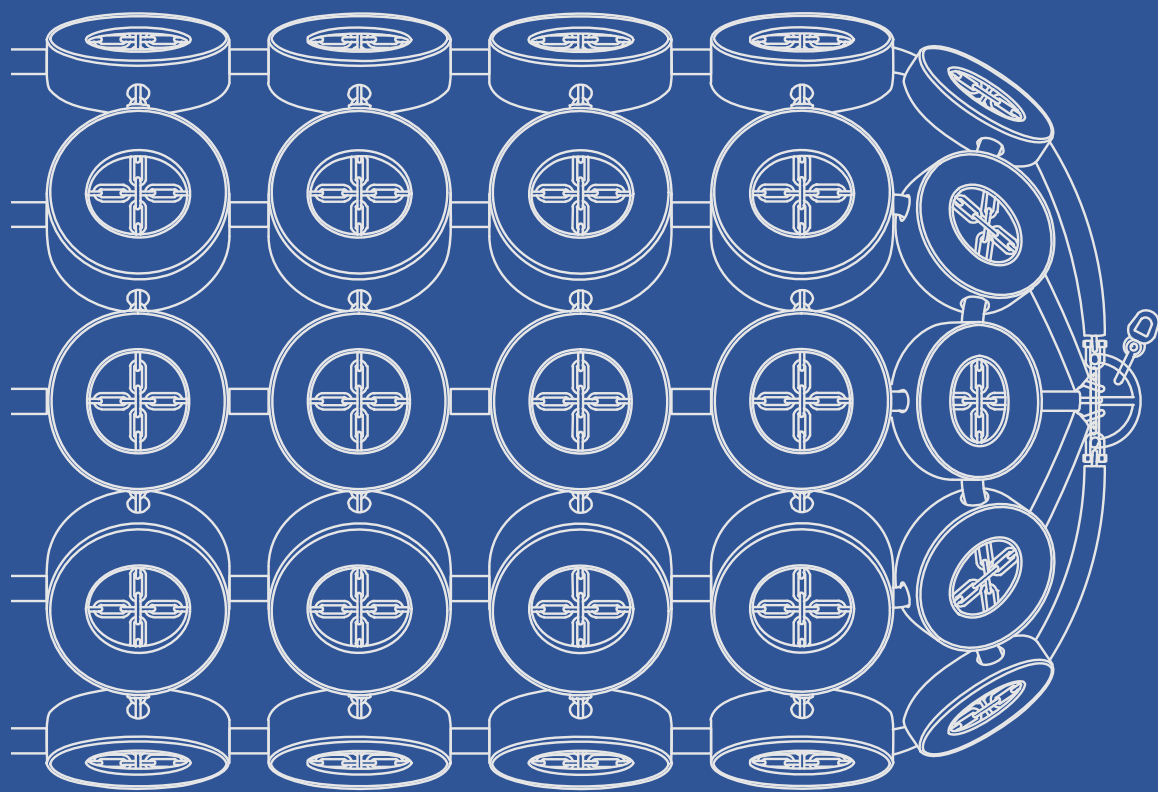

Pneumatic Fenders – Chart

50 kPa

Size	Energy Absorption	Reaction Force	Weight
Mm	kNm	kN	kg
700 x 1500	17	137	133
1000 x 1500	32	182	210
1000 x 2000	45	257	235
1200 x 2000	63	297	285
1500 x 3000	153	579	485
2000 x 3500	308	875	885
2500 x 3500	580	1208	1287
2500 x 4000	663	1380	1380
2500 x 5500	932	2010	1865
3000 x 5000	1050	2030	2266
3000 x 6000	1315	2488	2644
3300 x 4500	1180	1885	3180
3300 x 6500	1814	3015	3780
4500 x 6500	3432	4150	4982
4500 x 9000	4752	5747	6672

80 kPa

Size	Energy Absorption	Reaction Force	Weight
Mm	kNm	kN	kg
700 x 1500	21	171	143
1000 x 1500	40	266	226
1000 x 2000	56	321	255
1200 x 2000	79	371	309
1500 x 3000	191	724	549
2000 x 3500	385	1094	1003
2500 x 3500	726	1408	1405
2500 x 4000	829	1725	1580
2500 x 5500	1165	2513	2145
3000 x 5000	1313	2538	2626
3000 x 6000	1644	3110	3084
3300 x 4500	1640	2647	3560
3300 x 6500	2268	3769	4320
4500 x 6500	4518	4998	5990
4500 x 9000	6633	7551	9722

Performance is calculated at 60% compression. ISO17357-1: 2014

700 x 1500 – Pneumatic Fender

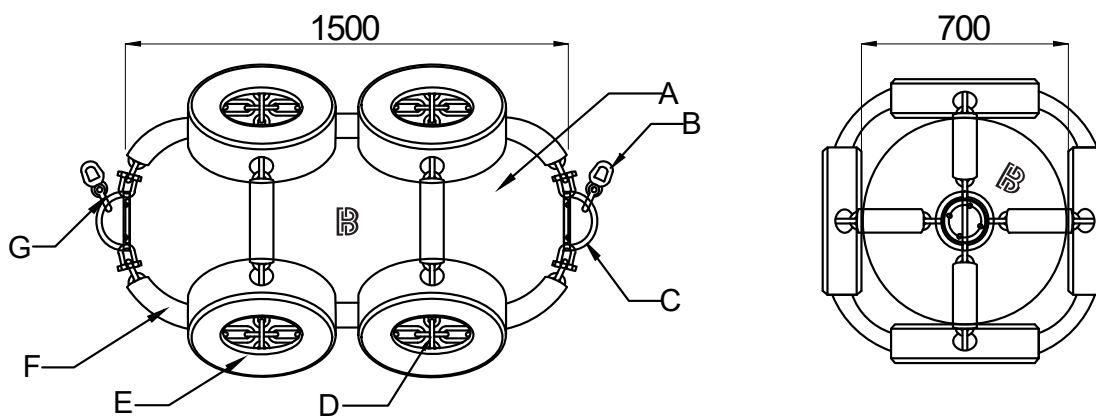

50 kPa	Value	80 kPa	Value
Energy Absorption	17 kNm	Energy Absorption	21 kNm
Reaction Force	137 kN	Reaction Force	171 kN
Weight	133 kgs	Weight	143 kgs
Initial Pressure	50 kPa	Initial Pressure	80 kPa
A	Fender Body (Rubber)	A	Fender Body (Rubber)
B	Swivel	B	Swivel
C	Pull Ring	C	Pull Ring
D	Chain	D	Chain
E	Tires	E	Tires
F	Rubber Sleeves	F	Rubber Sleeves
G	Shackle	G	Shackle

Performance is calculated at 60% compression. ISO17357-1: 2014

Weight unit is Kilograms. All measurements in mm. Measurements, weights, and drawings, are based on industry standards, and at 60% compression. A size tolerance of 5%, and other possible deviation margins need to be taken in mind.

Pneumatic Fender – 1000 x 1500

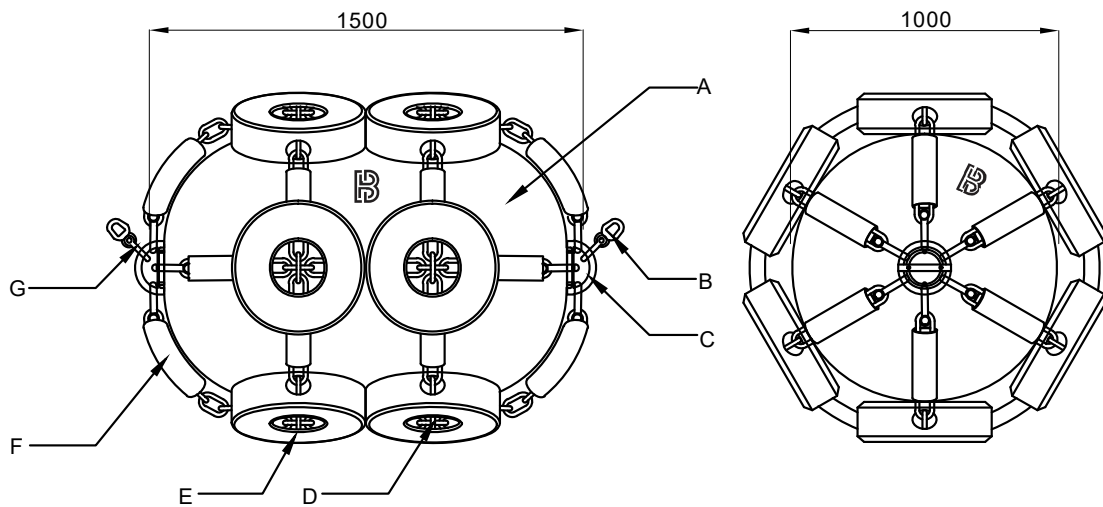

50 kPa	Value	80 kPa	Value
Energy Absorption	32 kNm	Energy Absorption	40 kNm
Reaction Force	181 kN	Reaction Force	266 kN
Weight	210 kgs	Weight	226 kgs
Initial Pressure	50 kPa	Initial Pressure	80 kPa
A	Fender Body (Rubber)	A	Fender Body (Rubber)
B	Swivel	B	Swivel
C	Pull Ring	C	Pull Ring
D	Chain	D	Chain
E	Tires	E	Tires
F	Rubber Sleeves	F	Rubber Sleeves
G	Shackle	G	Shackle

Performance is calculated at 60% compression. ISO17357-1: 2014



1000 x 2000 – Pneumatic Fender

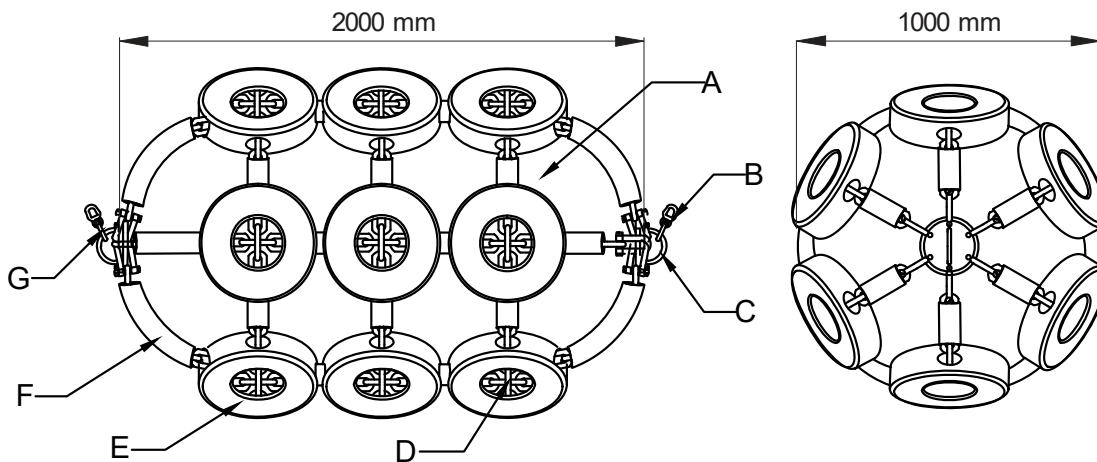

50 kPa	Value	80 kPa	Value
Energy Absorption	45 kNm	Energy Absorption	56 kNm
Reaction Force	257 kN	Reaction Force	321 kN
Weight	235 kgs	Weight	255 kgs
Initial Pressure	50 kPa	Initial Pressure	80 kPa
A	Fender Body (Rubber)	A	Fender Body (Rubber)
B	Swivel	B	Swivel
C	Pull Ring	C	Pull Ring
D	Chain	D	Chain
E	Tires	E	Tires
F	Rubber Sleeves	F	Rubber Sleeves
G	Shackle	G	Shackle

Performance is calculated at 60% compression. ISO17357-1: 2014

Weight unit is Kilograms. All measurements in mm. Measurements, weights, and drawings, are based on industry standards, and at 60% compression. A size tolerance of 5%, and other possible deviation margins need to be taken in mind.

Pneumatic Fender – 1200 x 2000

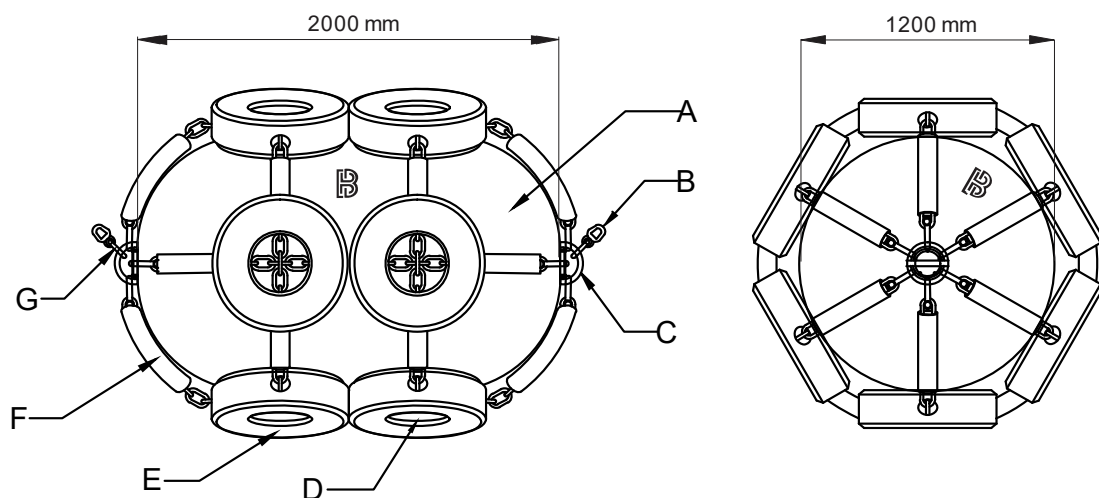

50 kPa	Value	80 kPa	Value
Energy Absorption	63 kNm	Energy Absorption	79 kNm
Reaction Force	297 kN	Reaction Force	371 kN
Weight	285 kgs	Weight	309 kgs
Initial Pressure	50 kPa	Initial Pressure	80 kPa
A	Fender Body (Rubber)	A	Fender Body (Rubber)
B	Swivel	B	Swivel
C	Pull Ring	C	Pull Ring
D	Chain	D	Chain
E	Tires	E	Tires
F	Rubber Sleeves	F	Rubber Sleeves
G	Shackle	G	Shackle

Performance is calculated at 60% compression. ISO17357-1: 2014



1500 x 3000 – Pneumatic Fender

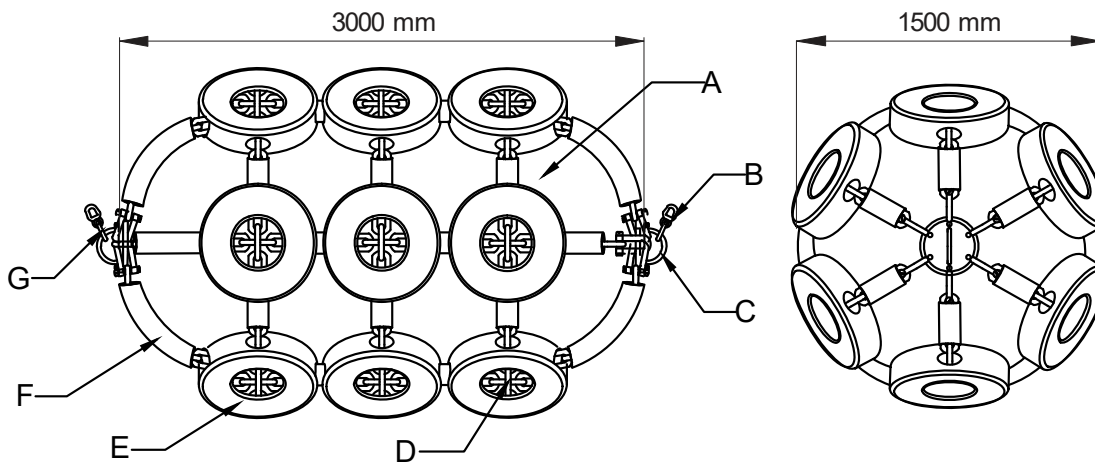

50 kPa	Value	80 kPa	Value
Energy Absorption	153 kNm	Energy Absorption	191 kNm
Reaction Force	579 kN	Reaction Force	724 kN
Weight	485 kgs	Weight	549 kgs
Initial Pressure	50 kPa	Initial Pressure	80 kPa
A	Fender Body (Rubber)	A	Fender Body (Rubber)
B	Swivel	B	Swivel
C	Pull Ring	C	Pull Ring
D	Chain	D	Chain
E	Tires	E	Tires
F	Rubber Sleeves	F	Rubber Sleeves
G	Shackle	G	Shackle

Performance is calculated at 60% compression. ISO17357-1: 2014

Weight unit is Kilograms. All measurements in mm. Measurements, weights, and drawings, are based on industry standards, and at 60% compression. A size tolerance of 5%, and other possible deviation margins need to be taken in mind.

Pneumatic Fender – 2000 x 3500

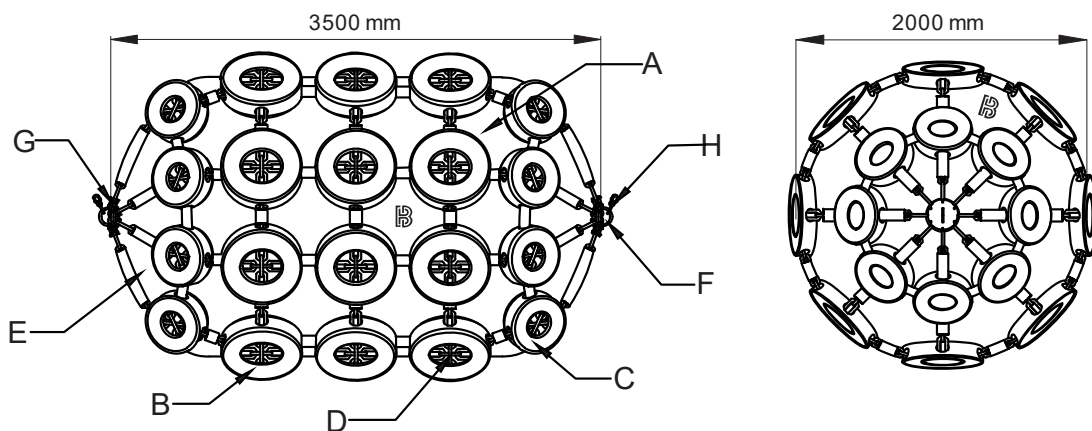

50 kPa	Value	80 kPa	Value
Energy Absorption	308 kNm	Energy Absorption	385 kNm
Reaction Force	875 kN	Reaction Force	1094 kN
Weight	885 kgs	Weight	1003 kgs
Initial Pressure	50 kPa	Initial Pressure	80 kPa
A	Fender Body (Rubber)	A	Fender Body (Rubber)
B	Tires	B	Tires
C	Shoulder Tires	C	Shoulder Tires
D	Chain	D	Chain
E	Rubber Sleeves	E	Rubber Sleeves
F	Pull Ring	F	Pull Ring
G	Shackle	G	Shackle
H	Swivel	H	Swivel

Performance is calculated at 60% compression. ISO17357-1: 2014



2500 x 3500 – Pneumatic Fender

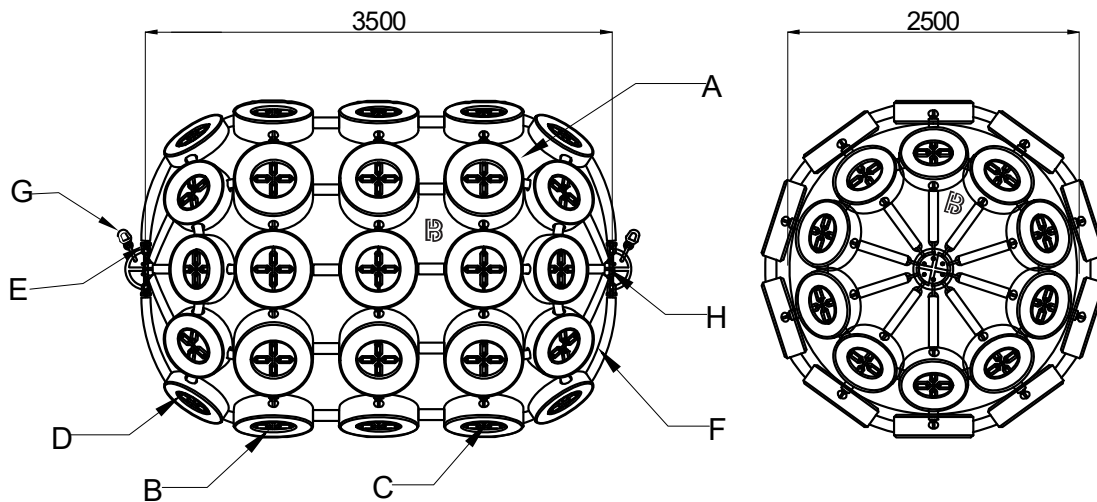

50 kPa	Value	80 kPa	Value
Energy Absorption	580 kNm	Energy Absorption	726 kNm
Reaction Force	1208 kN	Reaction Force	1408 kN
Weight	1287 kgs	Weight	1405 kgs
Initial Pressure	50 kPa	Initial Pressure	80 kPa
A	Fender Body (Rubber)	A	Fender Body (Rubber)
B	Tires	B	Tires
C	Chain	C	Chain
D	Shoulder Tires	D	Shoulder Tires
E	Shackle	E	Shackle
F	Rubber Sleeves	F	Rubber Sleeves
G	Swivel	G	Swivel
H	Pull Ring	H	Pull Ring

Performance is calculated at 60% compression. ISO17357-1: 2014

Weight unit is Kilograms. All measurements in mm. Measurements, weights, and drawings, are based on industry standards, and at 60% compression. A size tolerance of 5%, and other possible deviation margins need to be taken in mind.

Pneumatic Fender – 2500 x 4000

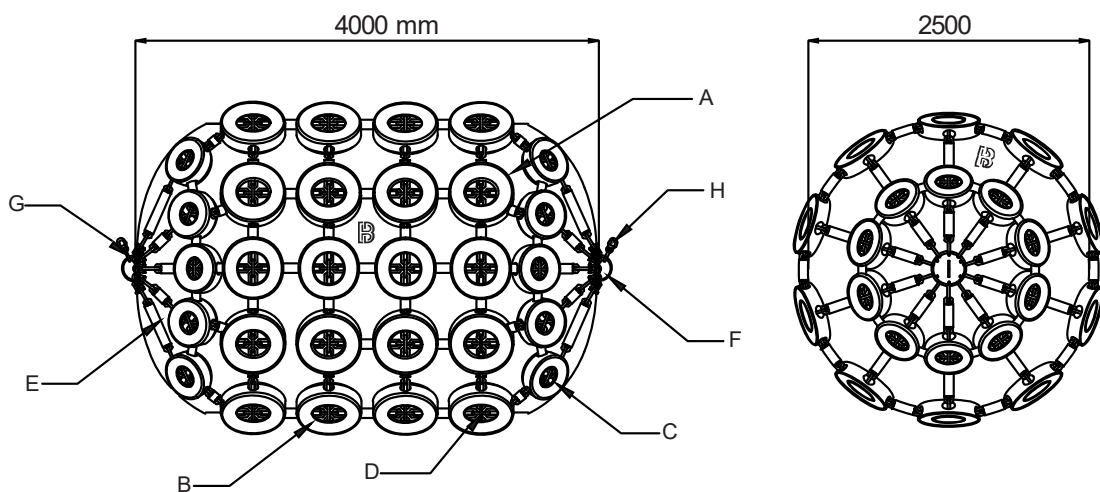

50 kPa	Value	80 kPa	Value
Energy Absorption	663 kNm	Energy Absorption	829 kNm
Reaction Force	1380 kN	Reaction Force	1725 kN
Weight	1380 kgs	Weight	1580 kgs
Initial Pressure	50 kPa	Initial Pressure	80 kPa
A	Fender Body (Rubber)	A	Fender Body (Rubber)
B	Tires	B	Tires
C	Shoulder Tires	C	Shoulder Tires
D	Chain	D	Chain
E	Rubber Sleeves	E	Rubber Sleeves
F	Pull Ring	F	Pull Ring
G	Shackle	G	Shackle
H	Swivel	H	Swivel

Performance is calculated at 60% compression. ISO17357-1: 2014



2500 x 5500 – Pneumatic Fender

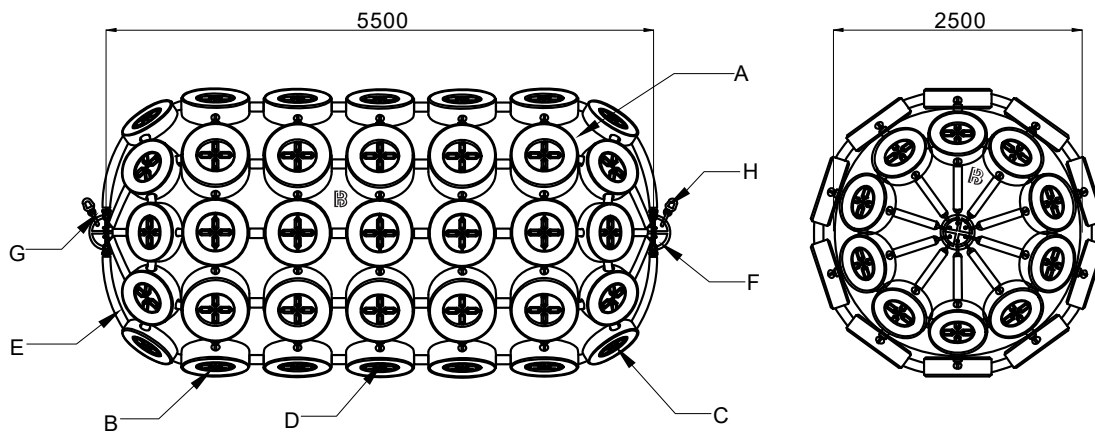

50 kPa	Value	80 kPa	Value
Energy Absorption	932 kNm	Energy Absorption	1165 kNm
Reaction Force	2010 kN	Reaction Force	2513 kN
Weight	1865 kgs	Weight	2145 kgs
Initial Pressure	50 kPa	Initial Pressure	80 kPa
A	Fender Body (Rubber)	A	Fender Body (Rubber)
B	Tires	B	Tires
C	Shoulder Tires	C	Shoulder Tires
D	Chain	D	Chain
E	Rubber Sleeves	E	Rubber Sleeves
F	Pull Ring	F	Pull Ring
G	Shackle	G	Shackle
H	Swivel	H	Swivel

Performance is calculated at 60% compression. ISO17357-1: 2014

Weight unit is Kilograms. All measurements in mm. Measurements, weights, and drawings, are based on industry standards, and at 60% compression. A size tolerance of 5%, and other possible deviation margins need to be taken in mind.

Pneumatic Fender – 3000 x 6000

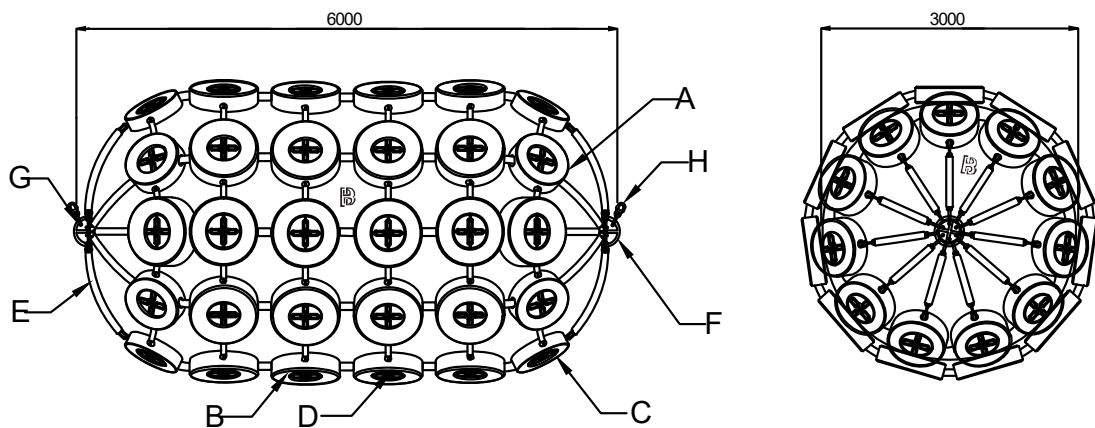

50 kPa	Value	80 kPa	Value
Energy Absorption	1315 kNm	Energy Absorption	1644 kNm
Reaction Force	2488 kN	Reaction Force	3110 kN
Weight	2644 kgs	Weight	3084 kgs
Initial Pressure	50 kPa	Initial Pressure	80 kPa
A	Fender Body (Rubber)	A	Fender Body (Rubber)
B	Tires	B	Tires
C	Shoulder Tires	C	Shoulder Tires
D	Chain	D	Chain
E	Rubber Sleeves	E	Rubber Sleeves
F	Pull Ring	F	Pull Ring
G	Shackle	G	Shackle
H	Swivel	H	Swivel

Performance is calculated at 60% compression. ISO17357-1: 2014



3300 x 4500 – Pneumatic Fender

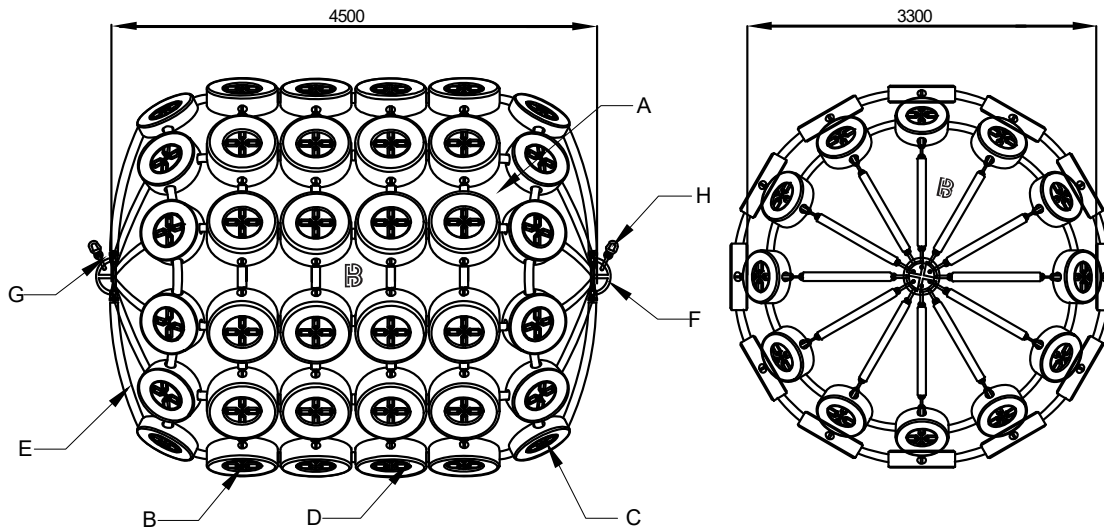

50 kPa	Value	80 kPa	Value
Energy Absorption	1175 kNm	Energy Absorption	1640 kNm
Reaction Force	1884 kN	Reaction Force	2467 kN
Weight	3180 kgs	Weight	3560 kgs
Initial Pressure	50 kPa	Initial Pressure	80 kPa
A	Fender Body (Rubber)	A	Fender Body (Rubber)
B	Tires	B	Tires
C	Shoulder Tires	C	Shoulder Tires
D	Chain	D	Chain
E	Rubber Sleeves	E	Rubber Sleeves
F	Pull Ring	F	Pull Ring
G	Shackle	G	Shackle
H	Swivel	H	Swivel

Performance is calculated at 60% compression. ISO17357-1: 2014

Weight unit is Kilograms. All measurements in mm. Measurements, weights, and drawings, are based on industry standards, and at 60% compression. A size tolerance of 5%, and other possible deviation margins need to be taken in mind.

Pneumatic Fender – 3300 x 6500

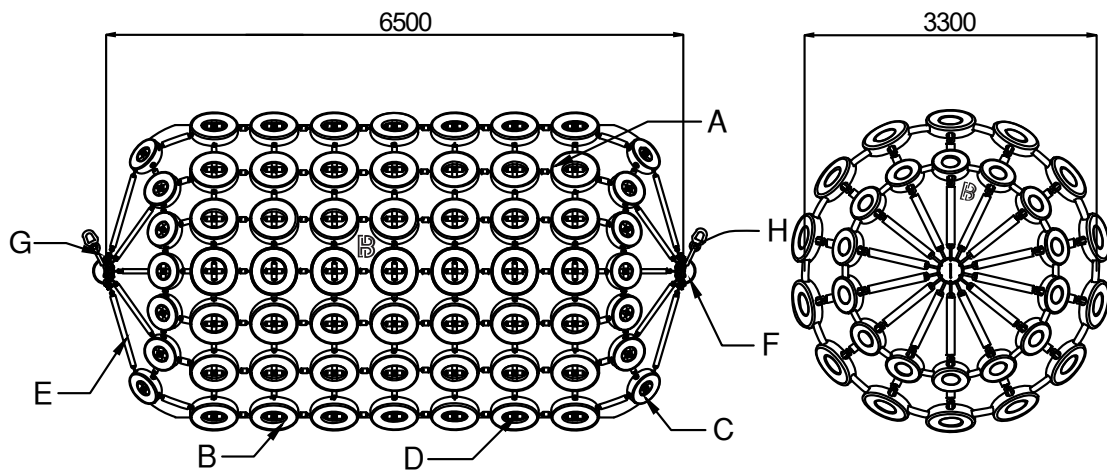

50 kPa	Value	80 kPa	Value
Energy Absorption	1814 kNm	Energy Absorption	2268 kNm
Reaction Force	3015 kN	Reaction Force	3769 kN
Weight	3780 kgs	Weight	4320 kgs
Initial Pressure	50 kPa	Initial Pressure	80 kPa
A	Fender Body (Rubber)	A	Fender Body (Rubber)
B	Tires	B	Tires
C	Shoulder Tires	C	Shoulder Tires
D	Chain	D	Chain
E	Rubber Sleeves	E	Rubber Sleeves
F	Pull Ring	F	Pull Ring
G	Shackle	G	Shackle
H	Swivel	H	Swivel

Performance is calculated at 60% compression. ISO17357-1: 2014



4500 x 6500 – Pneumatic Fender

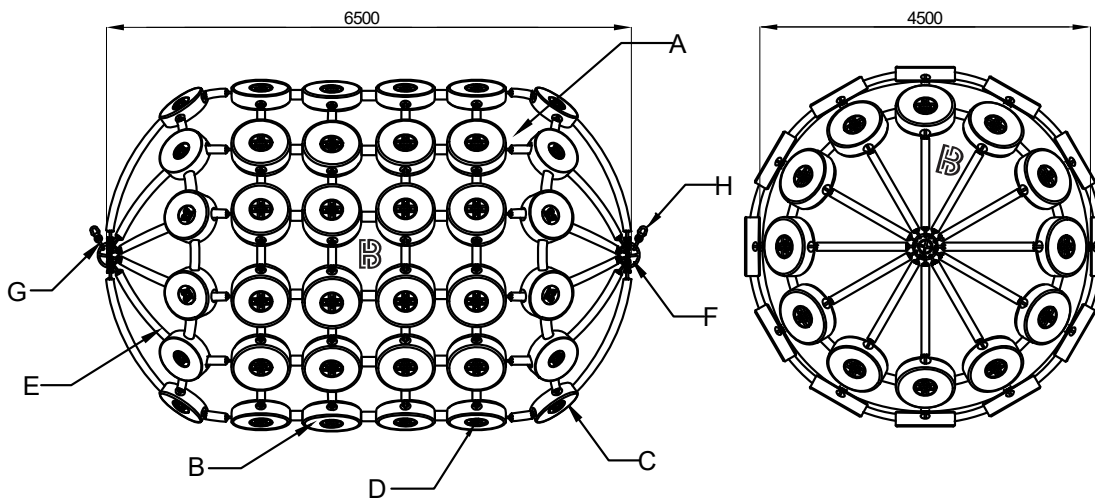

50 kPa	Value	80 kPa	Value
Energy Absorption	3432 kNm	Energy Absorption	4518 kNm
Reaction Force	4150 kN	Reaction Force	4998 kN
Weight	4982 kgs	Weight	5990 kgs
Initial Pressure	50 kPa	Initial Pressure	80 kPa
A	Fender Body (Rubber)	A	Fender Body (Rubber)
B	Tires	B	Tires
C	Shoulder Tires	C	Shoulder Tires
D	Chain	D	Chain
E	Rubber Sleeves	E	Rubber Sleeves
F	Pull Ring	F	Pull Ring
G	Shackle	G	Shackle
H	Swivel	H	Swivel

Performance is calculated at 60% compression. ISO17357-1: 2014

Weight unit is Kilograms. All measurements in mm. Measurements, weights, and drawings, are based on industry standards, and at 60% compression. A size tolerance of 5%, and other possible deviation margins need to be taken in mind.

Pneumatic Fender – 4500 x 9000

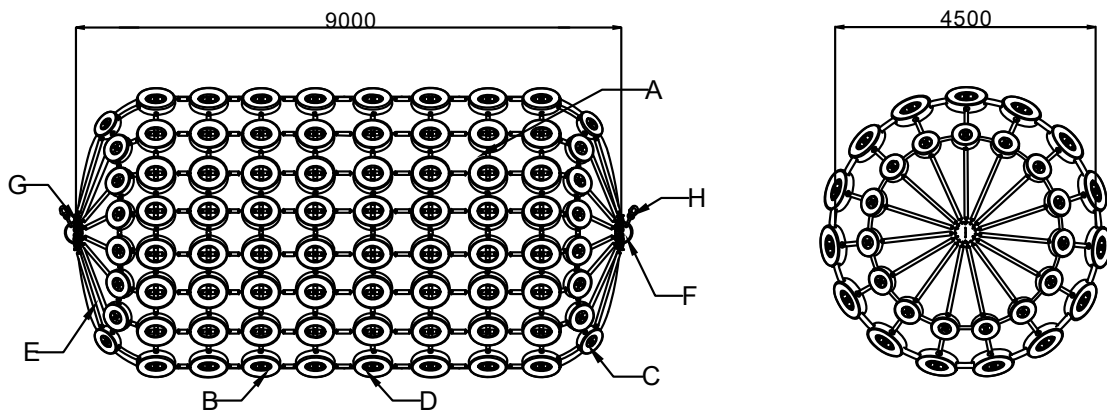

50 kPa	Value	80 kPa	Value
Energy Absorption	4752 kNm	Energy Absorption	6633 kNm
Reaction Force	5747 kN	Reaction Force	7551 kN
Weight	6672 kgs	Weight	9722 kgs
Initial Pressure	50 kPa	Initial Pressure	80 kPa
A	Fender Body (Rubber)	A	Fender Body (Rubber)
B	Tires	B	Tires
C	Shoulder Tires	C	Shoulder Tires
D	Chain	D	Chain
E	Rubber Sleeves	E	Rubber Sleeves
F	Pull Ring	F	Pull Ring
G	Shackle	G	Shackle
H	Swivel	H	Swivel

Performance is calculated at 60% compression. ISO17357-1: 2014